

since 1988

**AUDIO**  
**SYSTEM**

*german sound*

# HIGH-PERFORMANCE CAR-AMPLIFIER

OWNER'S MANUAL

**EX SERIES**  
BY AUDIO SYSTEM



X-80.6

X-170.4



**Congratulation on your purchase of your new X SERIES amplifier.**

**IMPORTANT:** Before installation your power amplifier, we recommend to read the owner's manual carefully and to follow the instructions regarding connection and fitting exactly.

**ATTENTION:** Pay attention to advices and instructions of the car manufacturer.

**IMPORTANT:** Your proof of purchase is evidence of warranty claim for repair or replacement. Keep your proof of purchase, manual and original packaging.

**ATTENTION:** Use of sound components can impair your ability to hear necessary traffic sounds and may constitute a hazard while driving your automobile.

**AUDIO SYSTEMGERMANY** accepts no liability for hearing loss, bodily injury or property damage as a result of use or misuse of our products. We recommend installing the equipment by an authorized service center or dealer. A professional fitting and connection is the requirement for further warranty and perfect sound.

**X-80.6**

- 6-Channel High Power Class-AB amplifier with SMD technology
- MOS-FET Power Supply
- Stable into 2 ohm stereo per channel and 4 ohm bridged mode
- Variable switchable Low Pass Filter from 45 to 4500 Hz
- Variable switchable High Pass Filter from 20 to 4500 Hz
- Variable switchable Band Pass Filter from 20 to 500 Hz and from 45 to 4500 Hz (LPF)
- 3-Way Full-Active-Mode possible
- **FSA** Front Stage adjuster for analog phase correction for the left front channel
- High-Level-Input with automatically „TURN ON“
- Very fast and steplessly adjustable Music Detection
- Input Sensitivity: variable 200 mV maximum to 8 V minimum
- Multi-Way Protection Circuitry: overheating, overcurrent and short circuitry
- Operating Voltage: DC 10 ~ 16 V Power Input
- Massive heavy aluminum-heatsink with included 3-step ON TOP ventilation system
- Wired Remote Controller **RTC** (Optional)



**X-170.4**

- 4-Channel High Power Class-AB amplifier with SMD technology
- MOS-FET Power Supply
- Stable into 2 ohm stereo per channel and 4 ohm bridged mode
- Variable switchable Low Pass Filter from 50 to 4000 Hz
- Variable switchable High Pass Filter from 20 to 4000 Hz
- Variable switchable Band Pass Filter from 20 to 500 Hz and from 50 to 4000 Hz (LPF)
- 2-Way Full-Active-Mode possible
- **FSA** Front Stage adjuster for analog phase correction for the left front channel
- High-Level-Input with automatically „TURN ON“
- 2CH / 4CH input mode selectable button
- Input Sensitivity: variable 200 mV maximum to 8 V minimum
- Multi-Way Protection Circuitry: overheating, overcurrent and short circuitry
- Operating Voltage: DC 10 ~ 16 V Power Input
- Massive heavy aluminum-heatsink with included 3-step ON TOP ventilation system
- Wired Remote Controller **RTC** (Optional)

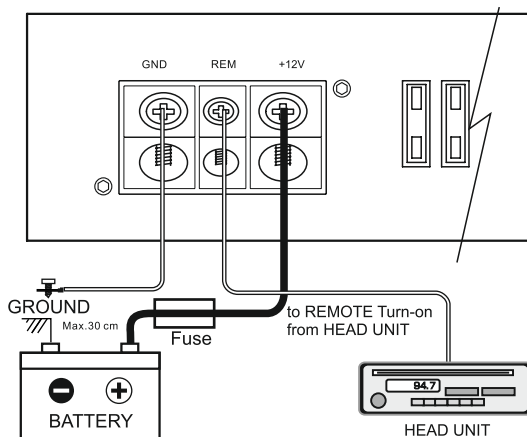

## X-80.6 / X-170.4

**1. Battery disconnection:**

First, disconnect the power supply of the vehicle by removing the ground cable of the battery.

**2. Ground connection:**

Connect the GND (ground) connection of the amplifier with the car chassis. Keep this cable as short as possible (not longer than 50 cm) and use a suitable cross section (AWG size 7-5).

Make sure, that the connection with the vehicle chassis is free of paint, dirt and dust.

**3. +12 V Power connection:**

Connect the +12 V contact of the amplifier with the supply cable via a fuse directly to the vehicle battery. Keep in mind, that the length of the cable from fuseholder to vehicle battery has to be maximum 30cm. For the amplifier to function at its best, use a high quality fuse holder and suitable cable preferably AWG 7-5 cable. This fuse protects the amplifier and the vehicle against the possibility of a short circuit in the power cable.

**4. Remote connection:**

Connect the REM-terminal of the amplifier to the remote-output (automatic 12 V antenna-output) of the head unit. Use a 0,5 - 1,5 mm power cable.



**Please follow the instructions during the installation of your amplifier:**

- Take care of a professional attachment. Pay attention, that no electrical cable, gas tank, hydraulic breakers or other components get damaged.
- There has to be enough cooling and air circulation. Avoid the installation in small closed boxes or close to heating parts.
- Protect the amplifier from fluids, wetness, heat and foreign material as well as from other influences.
- The amplifier is only to be built into vehicles with a 12 V DC power supply.
- Never install the power supply cable with other original wires of the vehicle (gas cables), fan motors, brand control moduls etc.
- Install the signal cable (cinch cable) as well as the speaker cable far away of the power cables to avoid troubles with the music signal.
- The cables of your amplifier have to be installed, so that there is no danger of binding, squeezing or breaking.

**X-80.6**

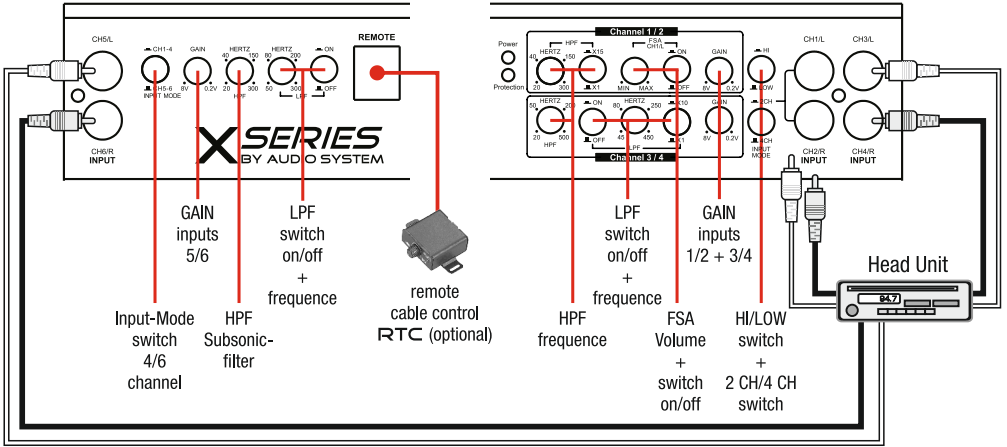

**X-170.4**

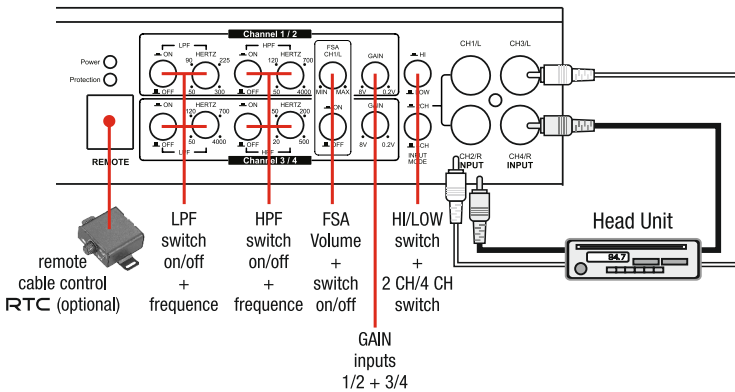

The **X SERIES** amplifiers have RCA inputs, which are connected by RCA cables to the preamp outputs of the head unit. If this is not possible (usually in an original radio, OEM) the speaker outputs of the car radio can be connected directly to the RCA / Cinch inputs of the amplifier. In this case, the Input Mode must be switched to "HI". It is important that the gain pots are first set to minimum and turned up carefully when handling. The power stage is automatically turned on when a signal is present. Accessories can be purchased in stores such as adapter cable **HLAC** and **RCA HI**. Using the variable high pass filter (HPF), low-pass filter (LPF), FSA (front stage adjuster - time delay at channel 1) the gain knob can be seen on his personal tastes, on the characteristics of the car and the speakers set the amplifier individually. At both amplifiers is also a fully active solution possible. Optionally, you can connect a wired remote **RTC** to control the output level of channels 3 + 4 (**X-170.4**) or channels 5 + 6 (**X-80.6**) (LP must be switched on).

**AUDIO SYSTEM GERMANY**, recommends that you leave your amplifier set by a specialist company, specialist dealer or a specialist to meet your needs.

## X-170.4 / X-80.6

### 4-Channel Stereo

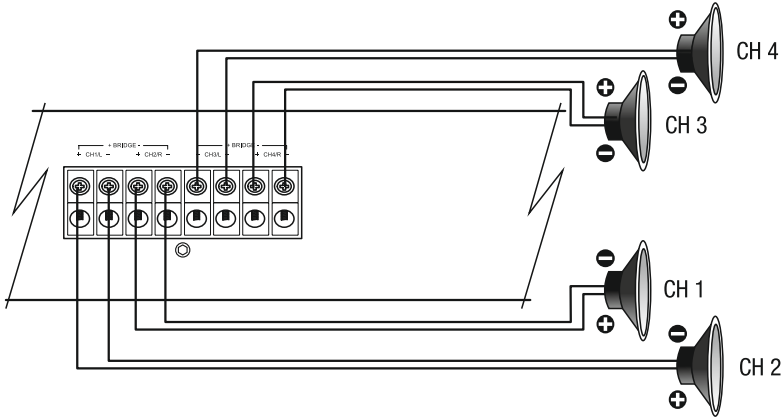

Speaker  
Impedance  
2 ~ 8 Ohm

### Stereo + Mono

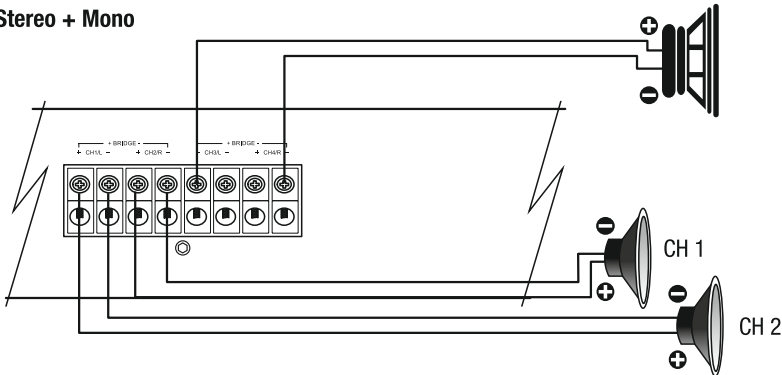

CH 3/4 Mono  
Subwoofer  
2 ~ 4 Ohm

Speaker  
Impedance  
2 ~ 8 Ohm

### Full-Active Mode

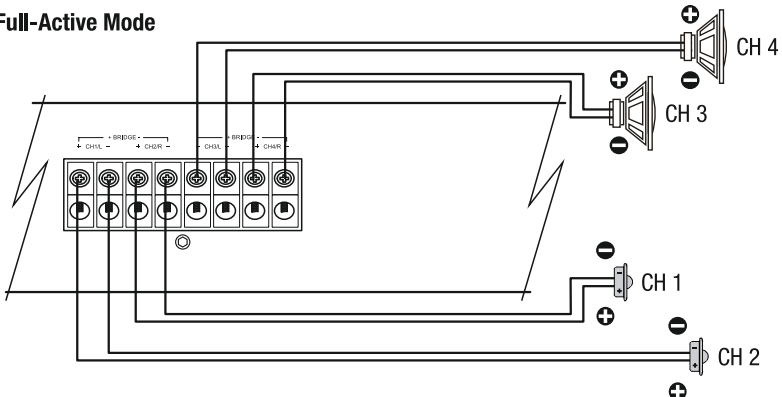

Speaker  
Impedance  
2 ~ 8 Ohm

At Full-Active Mode the high pass filter and low pass filter have to be adjusted confirming to the used midrange speaker and tweeter. **Therefore contact your specialist dealer.**

**X-80.6**

**Mono**

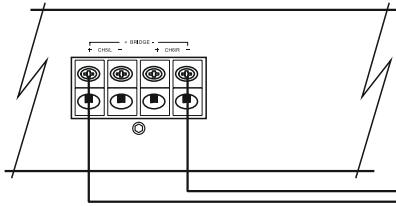

CH 5/6 Mono  
Subwoofer



Speaker  
Impedance  
4 ~ 8 Ohm

**Stereo**

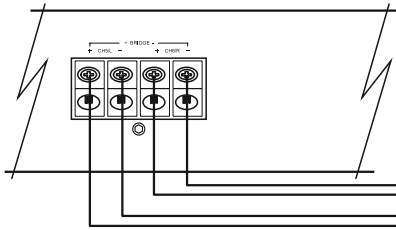

CH 5

CH 6

Speaker  
Impedance  
2 ~ 8 Ohm

This power amplifier is featured with an efficient protection system to prevent any damages like over-heating, overvoltage, short-circuit and DC at the loudspeaker output.  
 Occuring an error the protection-LED will light in red. In order to check the problem, first turn down all levels of the head unit, afterwards turn it off.

<p><b>AMPLIFIER IS NOT POWERED UP, NO LED IS LIGHTENING</b></p>	<ul style="list-style-type: none"> <li>- ground connection professional connected?</li> <li>- +12V powercable professional connected?</li> <li>- remote cable professional connected?</li> <li>- fuses inserted and alright?</li> <li>- analyze voltage on the amplifier.</li> </ul>
<p><b>PROTECTION LED ILLUMINATES GREEN WHILE AMPLIFIER IS SOUNDLESS</b></p>	<ul style="list-style-type: none"> <li>- cinch cable alrith and professional connected</li> <li>- loudspeaker professional connected?</li> <li>- head unit alright?</li> </ul>
<p><b>PROTECTION LED ILLUMINATES RED WHEN AMPLIFIER IS POWERED UP</b></p>	<ul style="list-style-type: none"> <li>- amplifier too hot?</li> <li>- short-circuit at the loudspeaker output?</li> <li>- short-circuit caused by loudspeaker cable with vehicle chassi (ground)?</li> <li>- input voltage too high (e.g.faulty generator)?</li> </ul>
<p><b>OVERHEATING (PROTECTION LED ILLUMINATES RED WHEN AMPLIFIER IS POWERED UP)</b></p>	<ul style="list-style-type: none"> <li>- impedance alright?</li> <li>- loudspeaker error?</li> <li>- adequate airflow of the amplifier?</li> </ul> <p style="text-align: center;"><b>! CAUTION !</b></p> <p style="text-align: center;"><b>After cooling down, the amplifier turns on automatically.</b></p>
<p><b>ERROR IN AMPLIFIER FUSE</b></p>	<ul style="list-style-type: none"> <li>- ground professional connected?</li> <li>- loudspeaker impedance alright?</li> </ul> <p style="text-align: center;"><b>! CAUTION !</b></p> <p style="text-align: center;"><b>Make sure when changing fuses to use the same value.</b></p>
<p><b>SOUND TOO LOW OR LOW-DISTORTED SOUND</b></p>	<ul style="list-style-type: none"> <li>- input level control "GAIN" is set to match the head unit?</li> <li>- output level control of the head unit alright?</li> <li>- loudspeaker error?</li> <li>- loudspeaker cable checked?</li> <li>- crossover frequencies has been properly set?                      (Check head unit, amplilfier, DSP, soundprozessor, equalizer, frequency bandpassfilter...)</li> </ul>
<p><b>HIGH HISS-ENGINE NOISE IN SPEAKERS</b></p>	<ul style="list-style-type: none"> <li>- ground connection professional connected?</li> <li>- short-circuit caused by loudspeaker cable with vehicle chassi (ground)?</li> <li>- cinchcable (RCA) and/or loudspeaker cabel installed too close to the power connection cable?</li> <li>- cinch ground (RCA) of the head unit alright?</li> </ul>

## ⚠ ATTENTION ⚠

Please contact your specialized dealer if the amplifier is still not working after it has been checked with the error list!

For warranty adjustement / repairs the original invoice has to be attached!  
**Opening the power amplifier is leading to a lost of warranty in either case!**

**6-CHANNEL AMPLIFIER**

Power Supply Voltage

Rated Power Output at 14,4 V

-RMS power @ 4 ohm stereo

-RMS power @ 2 ohm stereo

-RMS power @ 4 ohm bridged

Signal to Noise Ratio

Low Pass Crossover

High Pass Crossover / Subsonic filter

Frequency Response

THD@RMS Watts

Channel Separation

Fuse Rating

Input Sensitivity

Dimensions

**X-80.6**

10 -16 V

4x 80 W + 2x 150 W

4x 120 W + 2x 250 W

2x 240 W + 1x 500 W

&gt;90 dB

45 Hz ~ 4500 Hz

20 Hz ~ 4500 Hz

10 Hz ~ 80 KHz (+/- 1dB)

&lt; 0.02%

75 dB

3x 30 A

200 mV ~ 8V (+/- 5%)

420(L)x 50(H)x 185(W)mm

**4-CHANNEL AMPLIFIER**

Power Supply Voltage

Rated Power Output at 14,4 V

-RMS power @ 4 ohm stereo

-RMS power @ 2 ohm stereo

-RMS power @ 1 ohm stereo

-RMS power @ 4 ohm bridged

-RMS power @ 2 ohm bridged

Signal to Noise Ratio

Low Pass Crossover

High Pass Crossover / Subsonic Filter

Frequency Response

THD@RMS Watts

Channel Separation

Fuse Rating

Input Sensitivity

Dimensions

**X-170.4**

10 -16 V

4x 170 W

4x 300 W

4x 490 W

2x 600 W

2x 980 W

&gt; 90 dB

50 Hz ~ 4000 Hz

20 Hz ~ 4000 Hz

10 Hz ~ 95 KHz (+/- 1dB)

&lt; 0.018%

75 dB

5x 30 A

200 mV ~ 8V (+/- 5%)

580(L)x 50(H)x 185(W)mm



since 1988

**AUDIO SYSTEM**

german sound

AUDIO SYSTEM GERMANY  
FALLTORSTRASSE 6 - 76707 HAMBRÜCKEN

DESIGNED AND ENGINEERED BY AUDIO SYSTEM GERMANY